



**IMPORTANT – Each Ultra-HydroKleen is custom built to the dimensions you, the customer, provides. It is critical that every dimension be filled out on this worksheet and that this completed worksheet be sent with any purchase order to make sure the product will fit your catch basin.**

### SECTION A: Grate Measurement

1. In preparation for measuring your catch basin, remove the grate. Follow the directions for each step to ensure accuracy.
2. Measure the thickness of the grate. (t1) This measurement is always taken at the thickest point of the grate. Many times there will be a reinforcement bar cast into the bottom of the grate. Please fill in requested dimensions for t2, t3 and t4. If there is no reinforcing bar, only fill out (t1) and place the letters DNA (Does Not Apply) in (t2), (t3), and (t4).

Note the shape of the reinforcement bar as well as where it starts relative to the edge of the grate.

Also note if there is a casting flange next to edge of the grate and circle 'Yes' or 'No' in the box below

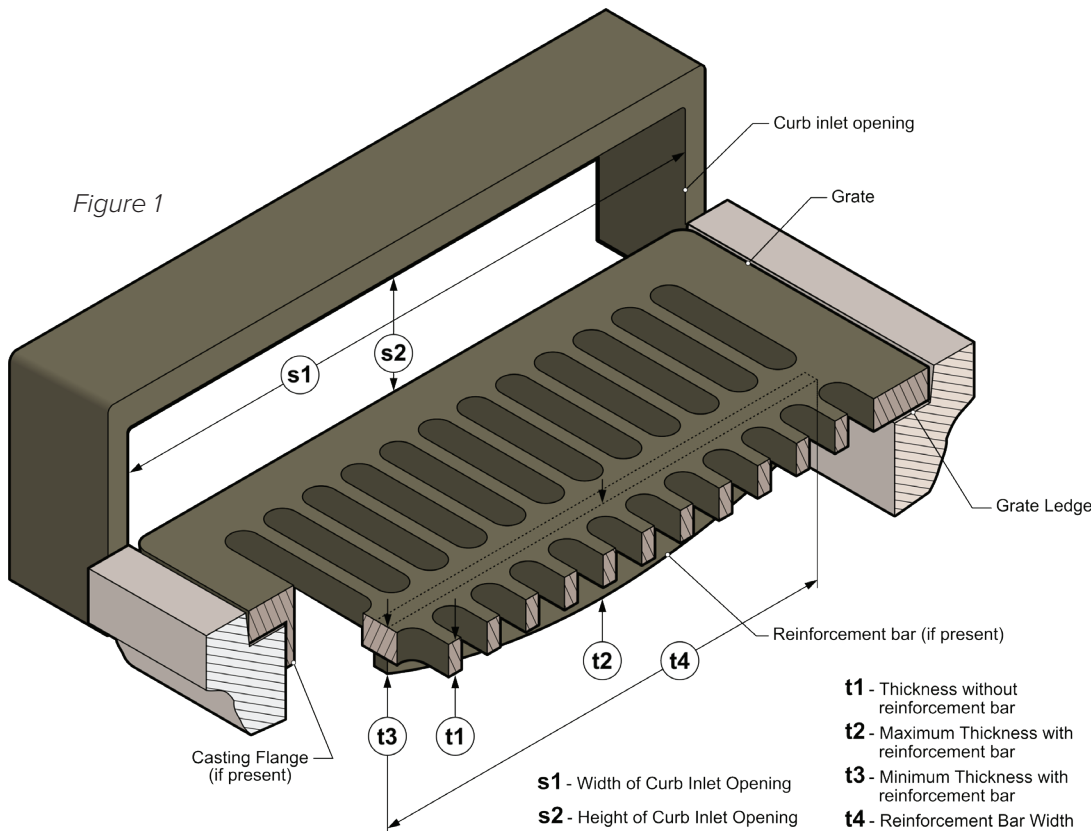

3. If the catch basin is a combination unit with a street grate and a curb opening combined, then measure the (s1) width of the curb opening and (s2) height of the curb opening so a properly sized diverter plate can be added to the Ultra-HydroKleen.

Casting Flange

Measurements

t1 = \_\_\_\_\_

t2 = \_\_\_\_\_

t3 = \_\_\_\_\_

t4 = \_\_\_\_\_

If applicable to your drain:

s1 = \_\_\_\_\_

s2 = \_\_\_\_\_

SECTION B: Catch Basin Measurements

1. Measure the distance from the ledge the grate sits on to the bottom of the catch basin. Enter this measurement as (d1). If the catch basin typically has standing water, measure from the ledge the grate sits on to the top of the water. Enter the measurement as (d2). Use the diagram and the space to the right to denote any abnormalities or obstructions in the side walls of the catch basin. Please use additional pages as necessary and attach to this measurement sheet. (See examples of obstructions on top of pg. 2)

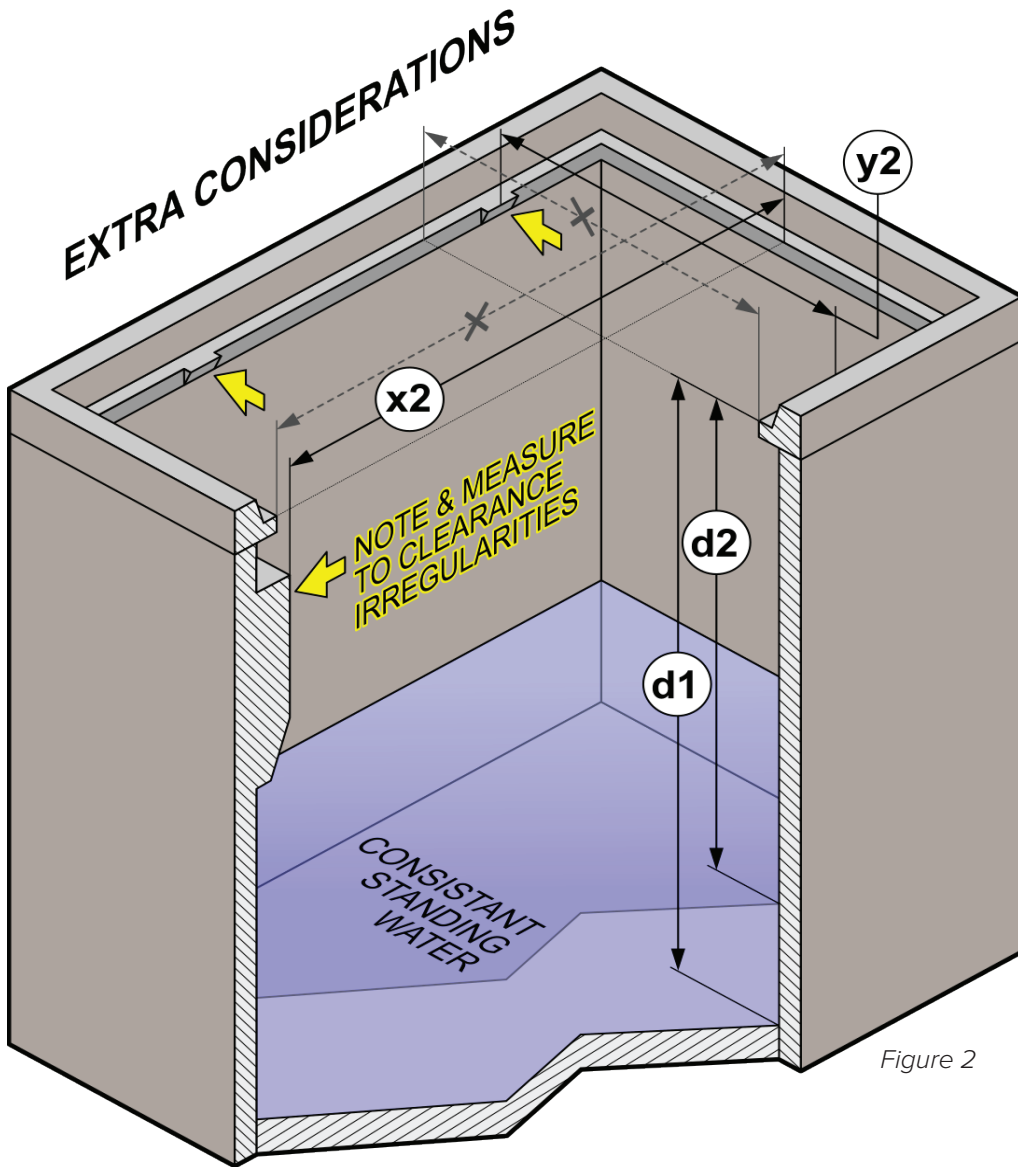

d1 = \_\_\_\_\_

d2 = \_\_\_\_\_

Measure distances x1 and y1. This measurement needs to be taken where the vertical wall of the grate ledge meets the horizontal wall of the grate ledge upon which the grate sits. (See Fig. 3 on next page)

Measure the distances x2 and y2. This is measuring the opening below the grate and is measured between the inside edges of the grate ledge upon which the grate sits. (See Fig. 3 on next page)

x1 = \_\_\_\_\_

y1 = \_\_\_\_\_

x2 = \_\_\_\_\_

y2 = \_\_\_\_\_

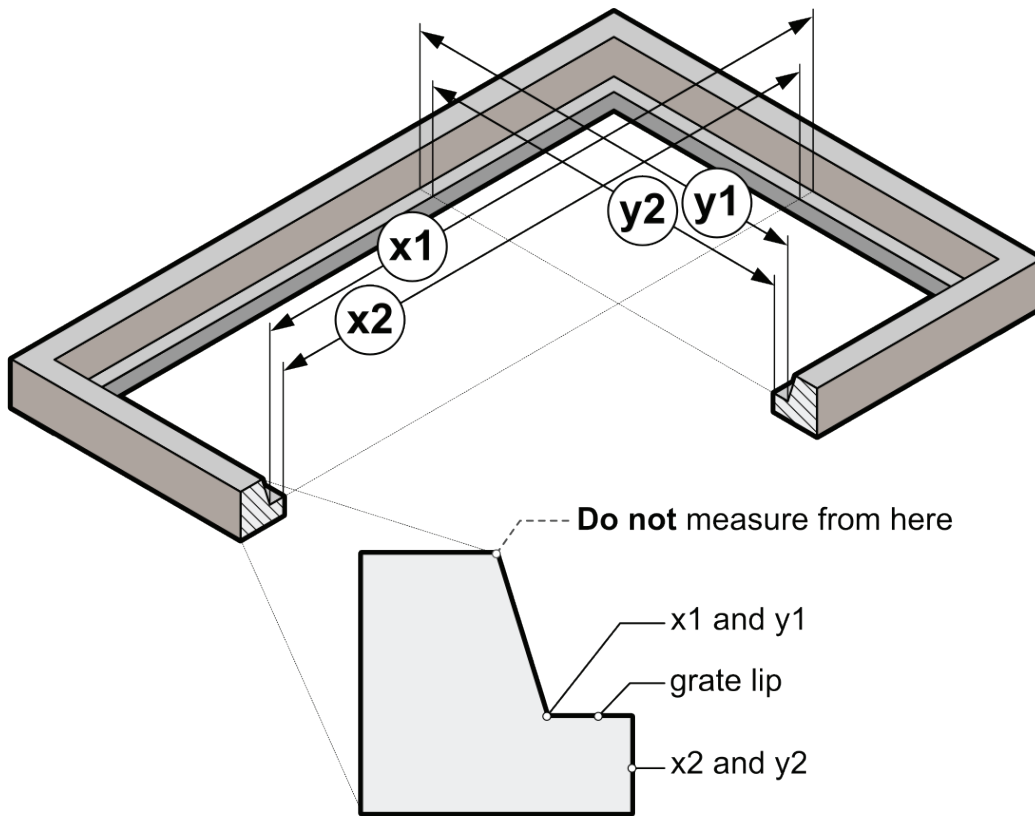

Figure 3

If there are any irregularities in the grate ledge, always measure at the narrowest point and describe the irregularities in the comment section below. (e.g.. In drawing to the right a flange in the middle of ledge protrudes 1" past rest of ledge)

**Examples of Obstructions and Irregularities**

(describe / draw in comments section below and/or additional pages)

- Measure how far any obstructions intrude into the catch basin interior space past the walls. Also measure the depth of the obstructions from the grate ledge.
- Note all ladders, inlet pipes, concrete protrusions, etc.
- Note if the grate frame is not centered over the catch basin or that the catch basin is narrower than the grate frame opening.

If the opening is round, measure across the center for x1 (on top of ledge) and x2 (between the ledge, measuring the opening to the catch basin below)

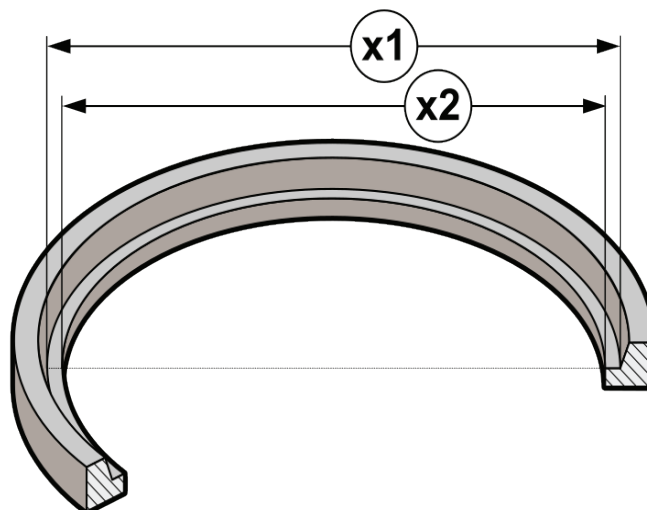

Comments: \_\_\_\_\_  
\_\_\_\_\_  
\_\_\_\_\_  
\_\_\_\_\_

**IMPORTANT: ALL DIMENSIONS MUST BE COMPLETED FOR AN ORDER TO BE PROCESSED. IF A SECTION DOES NOT APPLY TO YOUR PARTICULAR CATCH BASIN, PLEASE MARK IT 'DNA'. DO NOT LEAVE IT BLANK. THIS IS TO ENSURE THE PRODUCT WILL WORK AND FIT PROPERLY. IF A SECTION IS LEFT BLANK IT CAN DELAY THE MANUFACTURE OF THE HYDROKLEEN(S) ON YOUR ORDER WHILE WE CONTACT YOU FOR THE REQUESTED INFORMATION.**

Date:

Distributor name:

Customer name:

Customer site:

Measurements taken by: