



ULTRATECH
INTERNATIONAL, INC.

Products for a cleaner, safer, and more sustainable world.™

Track Pan Measurement Packet

The purpose of this packet is to ensure our Ultra-Track Pans will fit the intended application. In the case of polyethylene pans, it will also give us the measurements needed to help us determine which included component parts are necessary for installation.

There are four pages in this packet:

1. Rail Height Worksheet - *This is needed for all applications.*
2. Rail Width Worksheet - *This is needed for all applications.*
3. Pandrol/Vossloh clip Dimensions Worksheet - *This is only needed if pandrols or vossloh clips are present.*
4. Rail Curvature Worksheet - *This is necessary for any applications involving a curve.*

If you have any questions at all regarding this packet, please feel free to contact our Customer Service department at 904-292-1611 x 0 or customerservice@ultratechbrands.com



TIES & TRACK ATTACHMENT OPTIONS:

<p><u>TIES</u></p> <p>Please check one:</p> <p>WOOD CONCRETE STEEL</p>	<p><u>TRACK ATTACHMENT</u></p> <p>Please check one:</p> <p>SPIKES BOLTS PANDROL VOSSLOH</p>
---	---

Please fill out form on page 2 if you have chosen pandrols.

DRAWING & MEASUREMENTS:

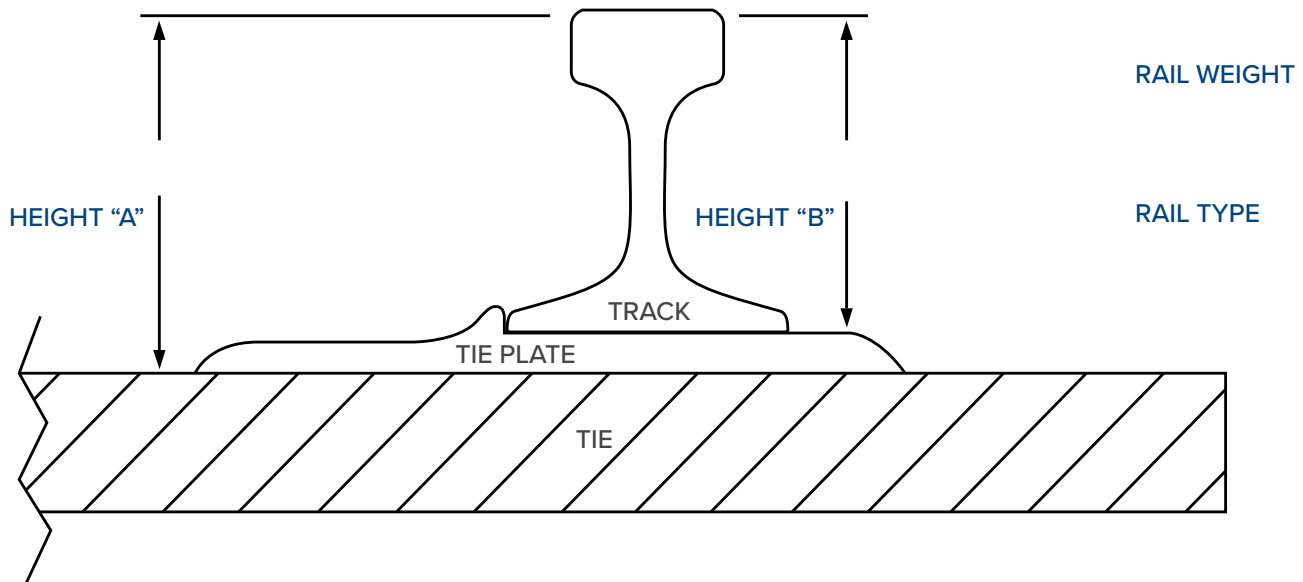

- How much containment is needed?
- How long of a system will be needed?
- Is this one system, or is this more than one system? (If more than one, how many?)
- Will drains be installed?
- Will the end user drive over the pans?
- When is the planned or target installation date?
- What is the substrate?
- What chemical/s need to be contained?
- Is the temperature of the substance being contained warmer than ambient temperature?
- Is there a curve to the rail where the pans will be installed?



WIDTH "X"

WIDTH "Y"

WIDTH "Z"

WIDTH "Y" SHOULD BE MEASURED BETWEEN THE TRACK RAIL WEB-TO-WEB.

WIDTH "Z" SHOULD BE MEASURED BETWEEN ANY OBSTRUCTIONS BETWEEN THE TRACKS, I.E., SPLICE PLATES AND HARDWARE.

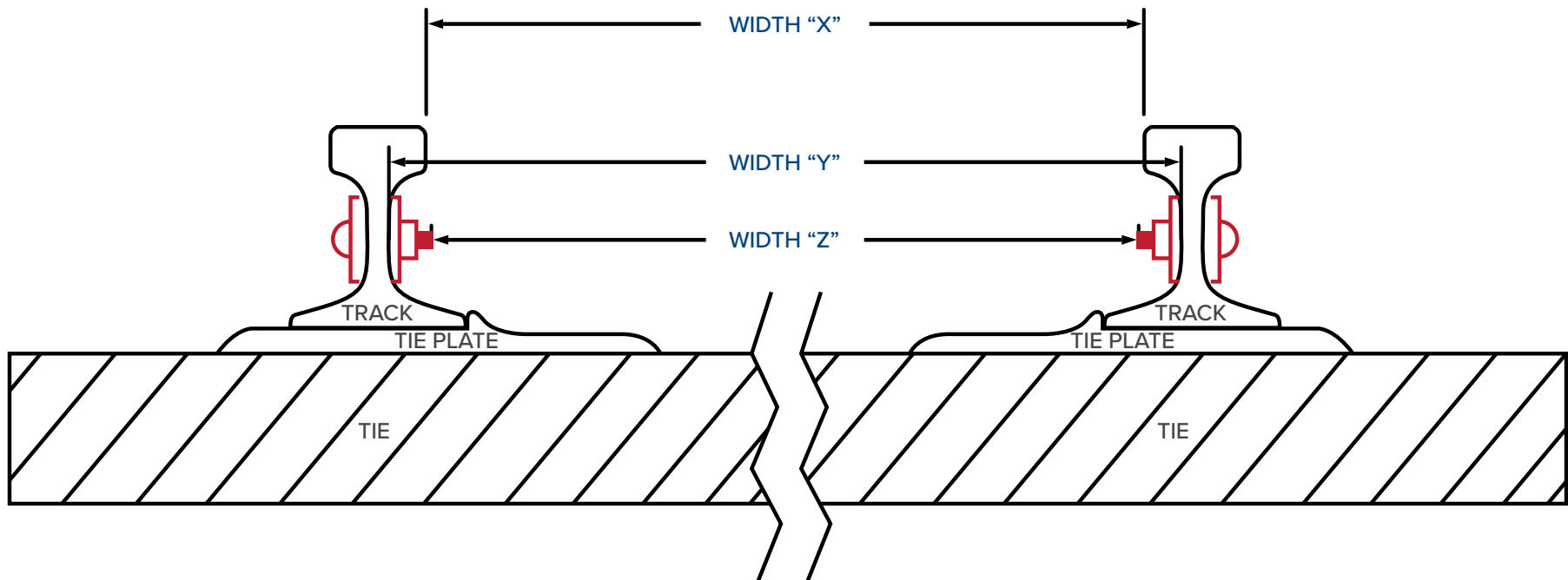



DRAWING & MEASUREMENTS:

Do NOT fill out this form unless you have pandrols or vossloh clips.

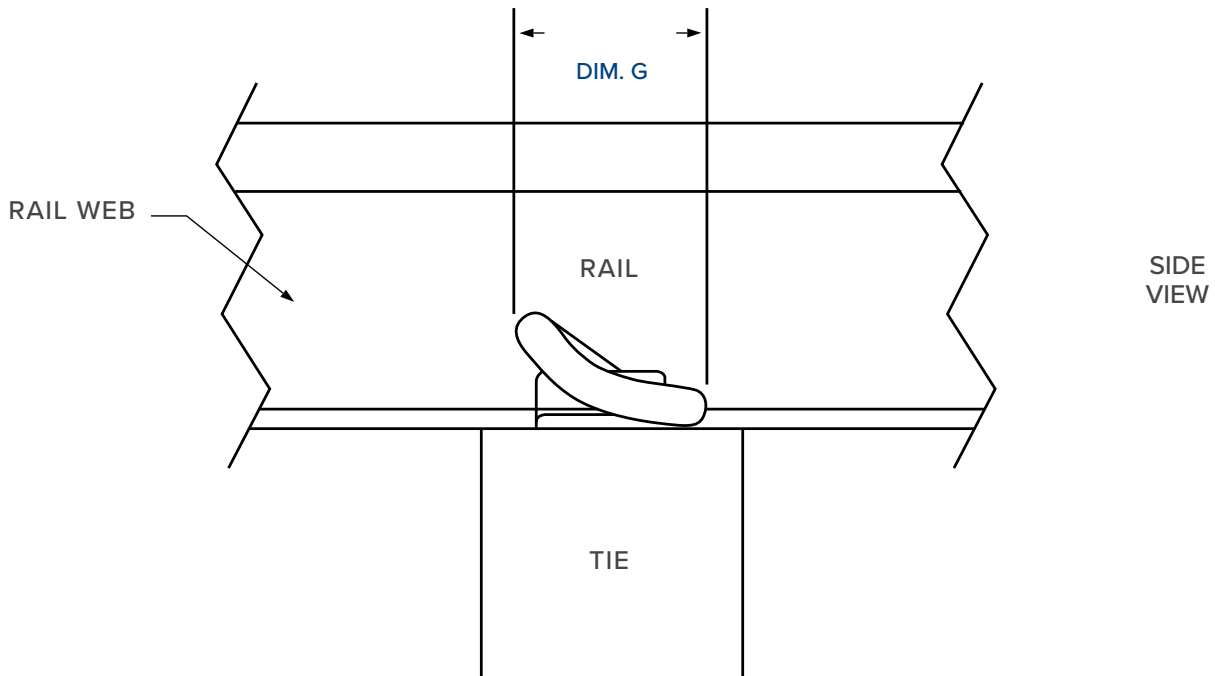
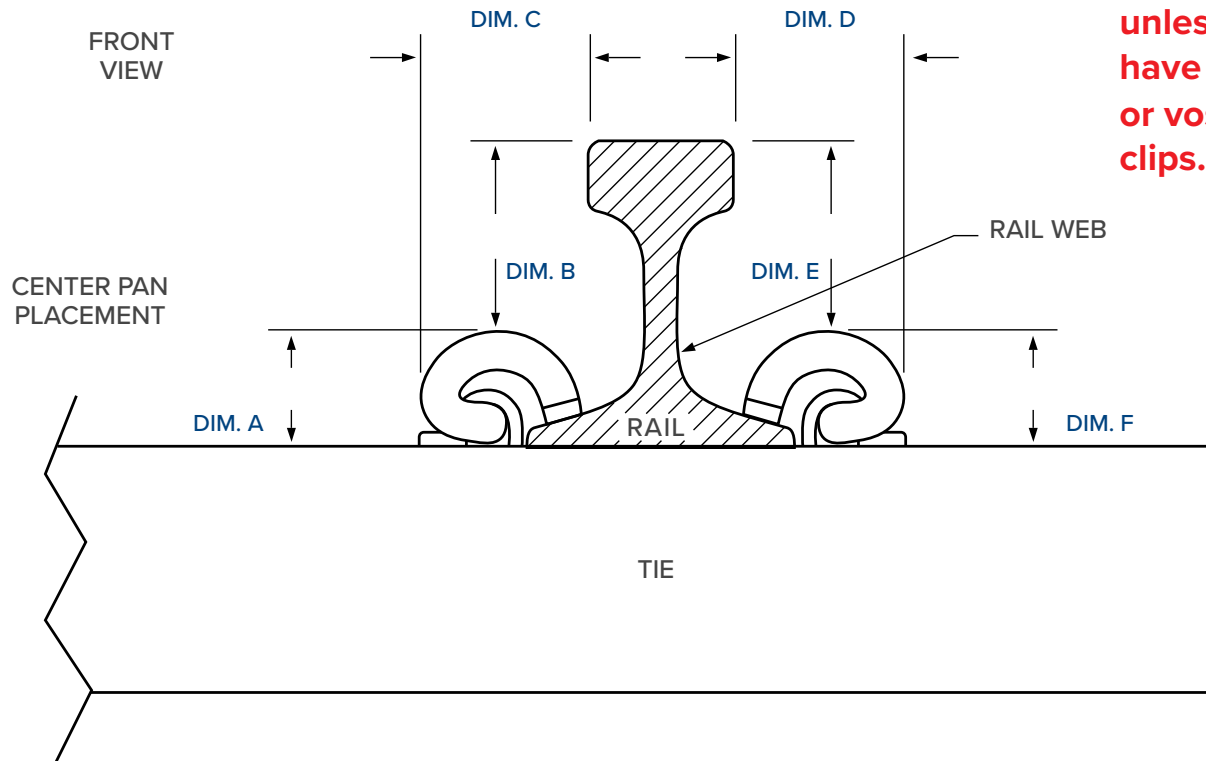

This drawing is not to be used for production purposes unless it has been initialed, dated and received with the current purchase order.

PO#:

Date:

Initial:

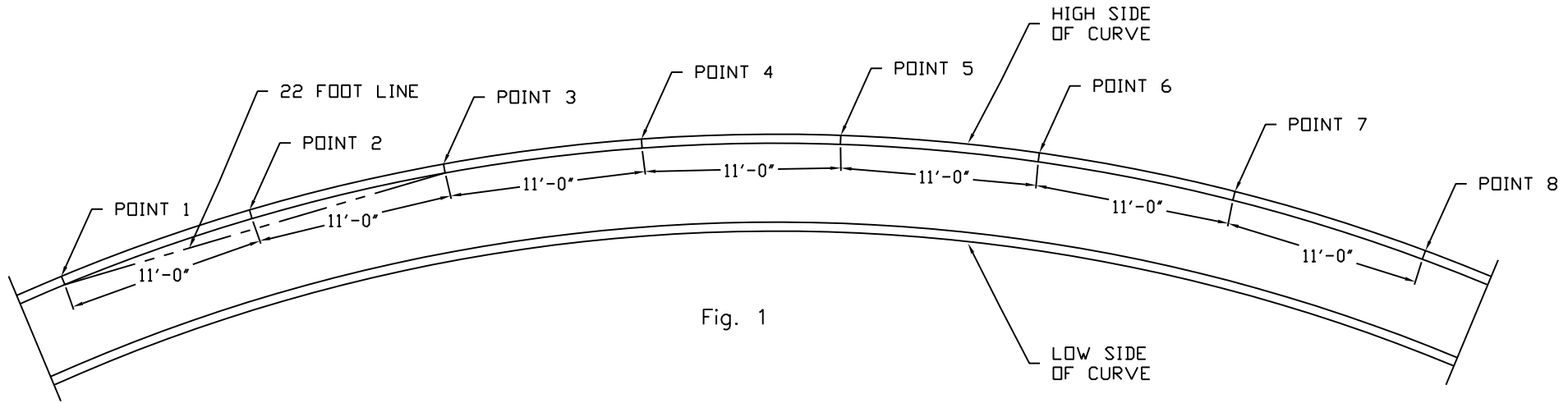

Fig. 1

Measuring Track Curvature

- 1) Starting at least 11' before the area where the TrackPan system will begin, mark several points on the inside face of the rail head on the high side of the curve, 11' apart. These Points should continue at least 11' past where the TrackPan system will end. (See Fig. 1)
- 2) Stretch a line (Chalk Line or twine e.g.) between Point 1 and Point 3 (22'). Measure the distance between the inside face of the rail head at Point 2 to the line (See Fig. 2). Always take these measurements at the inside face of the rail on the high side of the curve and round to the nearest $\frac{1}{8}$ ".
- 3) After taking the first measurement between Points 1 and 3 move the line to the next set of Points (2 and 4) and measure from the line to Point 3. Repeat these steps at each 11' Point until you have gone to the last set of Points. Record all measurements and submit to UltraTech International for conversion to Degree of Curvature at each Point.

Point 1	-	Meas.	<u> 0 </u> "
Point 2	-	Meas.	<u> </u>
Point 3	-	Meas.	<u> </u>
Point 4	-	Meas.	<u> </u>
Point 5	-	Meas.	<u> </u>
Point 6	-	Meas.	<u> </u>
Point 7	-	Meas.	<u> </u>
Point 8	-	Meas.	<u> </u>

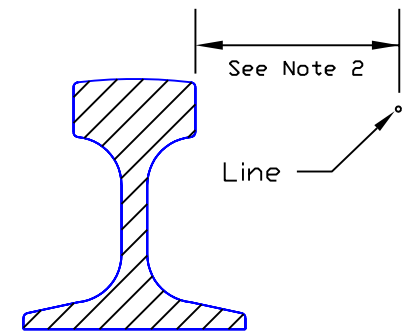

Fig. 2

CONFIDENTIAL
 This information and drawing is confidential and the property of UltraTech International, Inc. NO COPIES are to be made without express written permission from
 UltraTech International, Inc.