



**ULTRATECH**  
INTERNATIONAL, INC.

BMP

SWPPP

LEED

## Ultra-Drain Guard® Adjustable Frame Model

Ultra-Drain Guard stays in place even with grate removed

There are many models of Ultra-Drain Guard. And most of them are held in place by the weight of the storm drain grating. One exception to this is the adjustable frame model. Instead, this unit relies on a steel framework to keep it from falling into the basin. The steel framework adjusts to fit different drain sizes.

What is the advantage of this type of installation? For one thing, the Ultra-Drain Guard remains in place even when the grating is lifted. With other models, crews need the foresight to secure the Ultra-Drain Guard before lifting the grate. The other advantage is aesthetics. There is no excess material to trim or that may stick out above the grating. It's a clean and simple installation.

### Product Highlights

- + Adjustable catch basin insert quickly re-sizes to fit almost any storm drain – no trimming of excess fabric required.
- + Steel frame adjusts and keeps Ultra-Drain Guard in place – preventing it from falling into the basin even when the grate is lifted.
- + Heavy-duty hook-and-loop fasteners around the perimeter of the Ultra-Drain Guard skirt keeps it secured to the frame.
- + Quick and clean installation – no measuring or trimming required.
- + The steel frame can be reused - replacement filter fabric available and is quickly and easily installed.



ULTRA-  
**DRAIN GUARD**  
THE ORIGINAL CATCH BASIN INSERT

## Ultra-Drain Guard - Adjustable Frame Model

Part#	Model	Dimensions in. (mm)	Containment Capacity	Weight Capacity	Weight Lbs. (Kg)
8930	Adjustable Frame Model, 1-Pack	Min.: 16 x 20 x 18 (406 x 508 x 457) Max: 26 x 32 x 18 (660 x 813 x 458)	Up to 0.5 gal (1.9 L) of Oil	Up to 40 lbs. (18 kg) of Sediment	6.0 (2.7)
8931	Adjustable Frame Model, 10-Pack	Min.: 16 x 20 x 18 (406 x 508 x 457) Max: 26 x 32 x 18 (660 x 813 x 458)	Up to 0.5 gal (1.9 L) of Oil	Up to 40 lbs. (18 kg) of Sediment	6.0 (2.7)

### Option

Part#	Description
8932	Adjustable Frame Model, Replacement Filter Fabric, 10-Pack

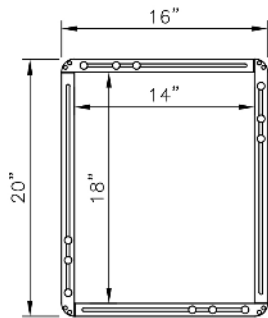

**ADJUSTABLE FRAME  
MINIMUM INLET SIZE  
(14"X18")**

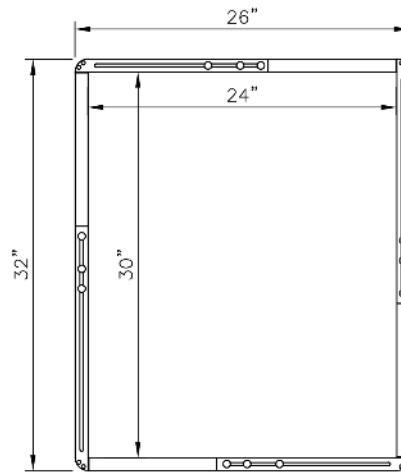

**ADJUSTABLE FRAME  
MAXIMUM INLET SIZE  
(24"X30")**

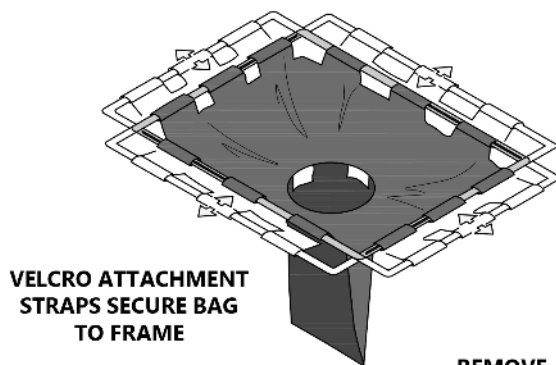

**VELCRO ATTACHMENT  
STRAPS SECURE BAG  
TO FRAME**

**REMOVE AND  
REPLACE BAG WHEN  
FULL OF SEDIMENT**

