



**TIES & TRACK ATTACHMENT OPTIONS:**

<p><u><b>TIES</b></u> Please check one:</p> <p>WOOD    CONCRETE    STEEL</p>	<p><u><b>TRACK ATTACHMENT</b></u> Please check one:</p> <p>SPIKES    BOLTS    PANDROL</p>
--	---

Please fill out form on page 2 if you have chosen pandrols.

**DRAWING & MEASUREMENTS:**

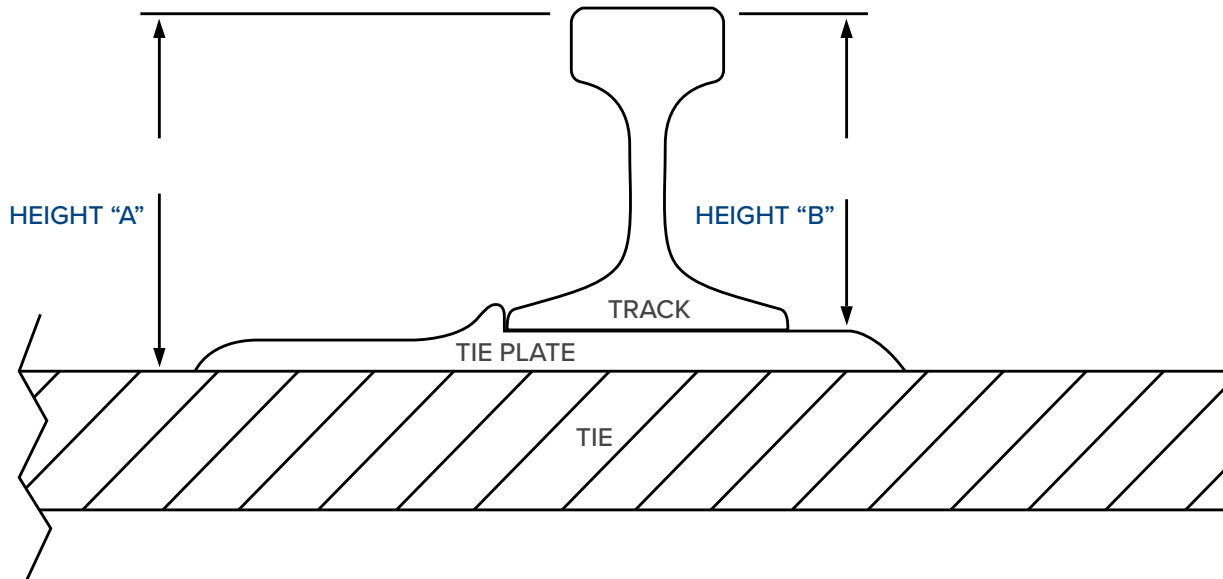

- How much containment is needed?
- How long of a system will be needed?
- Is this one system, or is this more than one system? (If more than one, how many?)
- Will drains be installed?
- Will the end user drive over the pans?
- When is the planned or target installation date?
- What is the substrate?
- What chemical/s need to be contained?
- Is the temperature of the substance being contained warmer than ambient temperature?



**DRAWING & MEASUREMENTS:**

**Do NOT fill out this form unless you have pandrols.**

