

Welding Gun

Safety Precautions

Please read this instructions carefully before use
The purpose of the precautions listed in this manual are to ensure the safe use of the machine and protect you and other from injury.

Safety is fully considered in the design and production of this product and the precautions in this manual must be observed during use.

Incorrect use of this product will cause hazard and injury of three different levels, to which warning symbols and test signals are used to warn in this manual.



Wire Spool Installation

1. Remove wire reel transparent cover
2. Unscrew the locking nut
3. Open the transparent cover of handle
4. Pull up pressing arm
5. Pull the wire feeding wheel

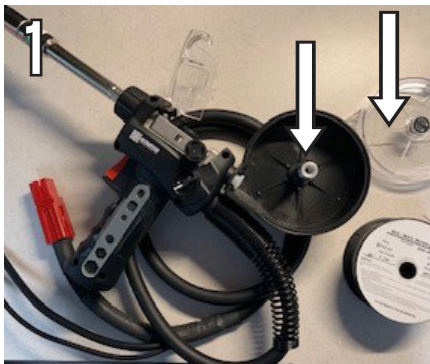

Wire Installation

1. Unscrew front nose and wire spring
2. Insert flux wire, insert the spool in the gun and screw the nut to secure the spool
3. Feed 10" of wire into the front nozzle
4. After welding wire reel is mounted, the locking nut shall be screwed tightly enough to prevent the risk of wire blasting of the welding wire reel. This nut controls the wire tension.

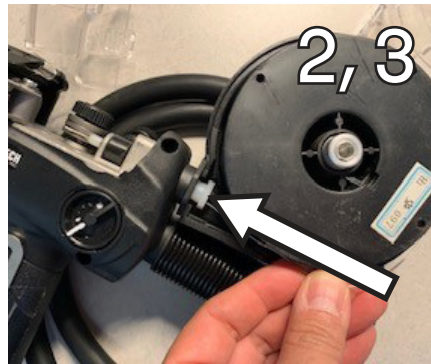

5. Close the wheel pressing arm, clamp the regulating lever into the wheel pressing arm groove
6. Screw the tension regulating lever tightly
NOTE: Gun is set up this the wire wheel groove for 0.030 to 0.35 wire, to feed 0.040+ you need to turn the wheel.
7. Untighten the compression nut
8. Turn and place back
9. Install the compression nut and tighten

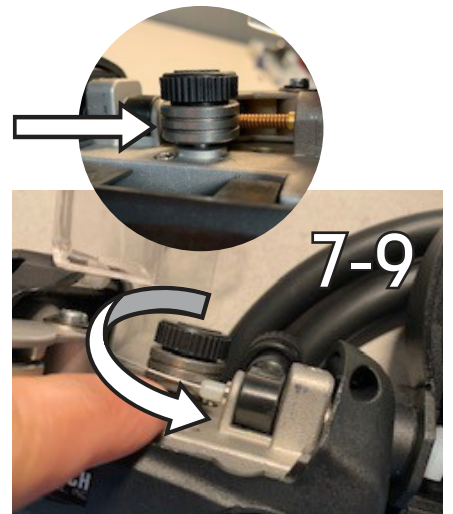
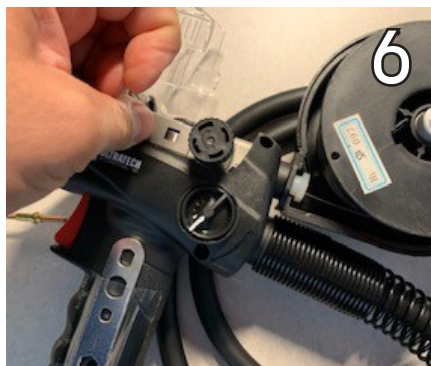

Flux Wire and Welding Tip

1. Insert the wire into the spring following the nozzle
2. Insert the welding tip

NOTE: Choose the right tip for the right wire to prevent wire from back welding into the tip.

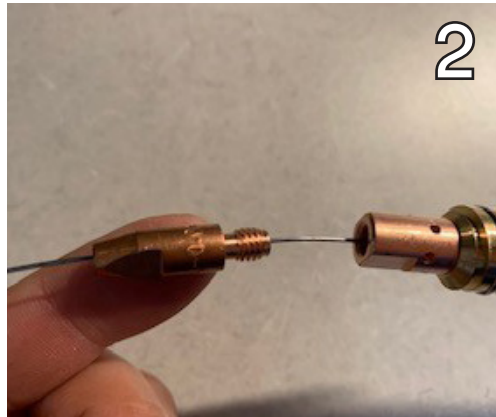
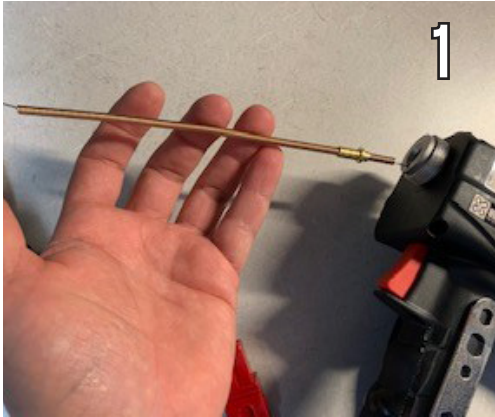

Wire Speed

Wire speed knob is set up to increase speed by turning right and slow down to the left.